

SVCam-svs4050

SVCam-HR Line

4 Megapixel Camera with high speed dual Gigabit Ethernet connection

Pre-liminary



This digital Machine Vision camera has a resolution of 2336 x 1752 pixels. It is designed to reach high frame rates in a compact housing. The camera is based on a high-quality interline CCD from Kodak which offers 4 tap outputs. The number of taps are selectable. To further increase the maximum frame speed SVS-VISTEK has created an innovative 2 Gigabit output model. This version allows 4 Megapixel of full images to be captured at up to 32 frames per second.

Correlated Double Sampling (CDS) and 4 x 14 Bit A/D Converters guarantee an excellent signal-to-noise ratio.

The internal logic allows different ways to adjust exposure time and select trigger modes including:

- > Synchronization of image capture to an external event
- > "Free running" with adjustable frame rate
- > Via Ethernet interface or trigger pulse
- > Longer exposure times under low light conditions

The camera can work fully compliant with GigE Vision standard. In addition dual GigE complies with Link Aggregation (LAG) standard.

GEN<i>CAM

GiGE
VISION

Technical Highlights/Technical Data

- | | |
|---|--|
| <ul style="list-style-type: none"> > Progressive Scan technology > Resolution: 2336 x 1752 pixel > Synchronization: <ul style="list-style-type: none"> · "Free running" (frame rate adjustable) · External trigger with internal exposure control · External trigger with pulse width exposure control · Software trigger via PC > Housing dimensions: 70mm x 71mm x 49.5mm > Monochrome and color sensors (Bayer Pattern) > Up to 12 Bit video data stream (14 Bit ADC per tap) > 256 MB Memory | <ul style="list-style-type: none"> > Internal LUT operations > Internal flat-field correction > Adjustable gain > Low offset > 2 x 2 binning mode > Area of Interest (AOI) > M42 x 1 Mount (standard F-Mount adapter) > Operating temperature range: -10°C to +45°C > Broad voltage input possible (+10V to +25V DC) > Full 2 years warranty |
|---|--|

Overview

SVCam-svs4050

Camera Type	svs4050XFLGEC	svs4050XFLGEA
Tap Selection	4 tap (with 2 GigE channels)	4 tap (with 2 GigE channels)
Resolution	2336 x 1752	2336 x 1752
Frame Rate (Hz, max.)	32*	41*
Pixel (μm^2)	5.5 x 5.5	5.5 x 5.5
CCD diagonal 1"	4:3 Aspect Ratio	4:3 Aspect Ratio
Exposure Time internal	100 μs - 2 s	100 μs - 2 s
Exposure Time external	100 μs - ∞	100 μs - ∞

* 4 x 48 MHz; X = Monochrome, X = Color

For more camera types see our SVCam-HR product overview.

Operation Modes

Mode: Free Running/Fixed Frequency

In this mode the camera creates all sync signals itself. Camera is connected to PC and will create images immediately.

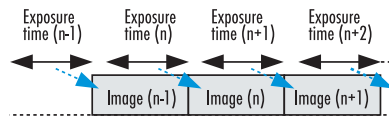

Mode: External Trigger, Internal Exposure Control

The camera needs an external trigger to output images. The exposure time is set by the internal logic inside the camera.

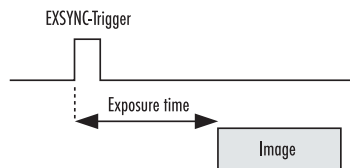

Mode: External Trigger, External Exposure Control

The camera needs an external trigger to output images. The exposure time is determined by the pulse width of the trigger signal and can be changed from frame to frame.

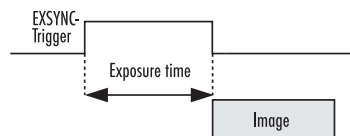

Mode: Software Trigger

The PC sends a command to the camera in order to get data. Internal logic is set for the exposure time. Jitter must be observed.

Dimensions [mm]

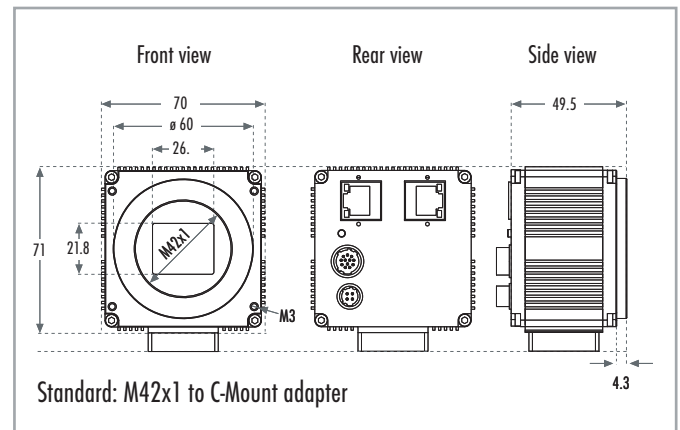

HR10A-10R-12PB (mating connector HR10A-10P-12S)

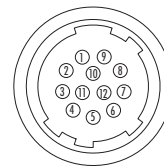

- | | |
|------------------------|------------------------|
| 1 VIN- (GND) | 7 OUT1 (TTL Level) |
| 2 VIN+ (10V to 25V DC) | 8 OUT2 (TTL Level) |
| 3 RXD (RS232 Level) | 9 IN3+ (RS422 Level) |
| 4 TXD (RS232 Level) | 10 IN3- (RS422 Level) |
| 5 IN1 (TTL Level) | 11 OUT3+ (RS422 Level) |
| 6 IN2 (TTL Level) | 12 OUT3- (RS422 Level) |

HR10A-7R-4PB (mating connector HR10A-7P-4S)

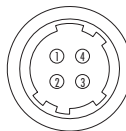

- | |
|------------------------|
| 1 VIN+ (10V to 25V DC) |
| 2 VIN- (GND) |
| 3 IN0 (TTL Level) |
| 4 OUT0 (TTL Level) |

Configuration Software

The SVCam cameras come with our "SVCapture"-software, which allows easy interactive setup of all camera parameters. The program runs under Windows 7 but also 64 Bit mode. Linux is supported as well. A XML file compliant with the GenICam standard is supplied with the camera. The free SDK and API coming with the camera allows easy integration into an application without involving frame grabber driver.

Ordering Guide

Monochrome: **svs4050MFLGEC** Color: **svs4050CFLGEC** (max. 32Hz)
svs4050MFLGEA **svs4050CFLGEA** (max. 41Hz)

Standard: M42x1 to C-Mount adapter
 Option: M42x1 to F-Mount adapter

